

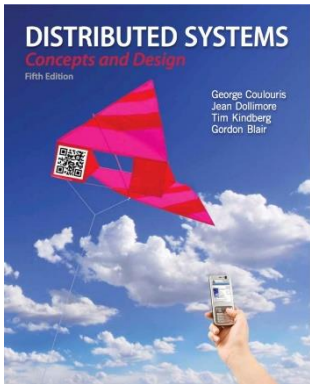

Name Services



Dr. Minxian Xu

Associate Professor

Research Center for Cloud Computing

Shenzhen Institute of Advanced Technology, CAS

<http://www.minxianxu.info/dcp>

Most concepts are
drawn from Chapter 13

苍壁丹崖几万寻，飞鸟回旋不知路。路逢樵者问山名，山深只为无名故。
——（明）邵宝

Review

- Q1. What are the 3 types of operating systems?

Review



Review

- Q2: What are advantages and disadvantages of Monolithic OS?

Review



Review

- Q3: What are the advantages of microkernel-based OS?

Review



Review

- Q4: Give some examples of microkernel systems?

Review



Which one is easy for humans and machines? and why?



- 74.125.237.83 or **google.com**
- 185.230.63.171 or distributed computing principles
- 128.250.1.25 or **Dr. Xu**
- Disk 4, Sector 2, block 5 OR /usr/mx/Hello.java
- mx@128.250.1.25 or **mx.xu@siat.ac.cn**

Names or Codes, or Numbers?

- Names (when meaningful) are easier to remember than codes or numbers...
- Number (or sequence codes) are more useful for structuring data and locating resources by a program..
- Example: IPv4

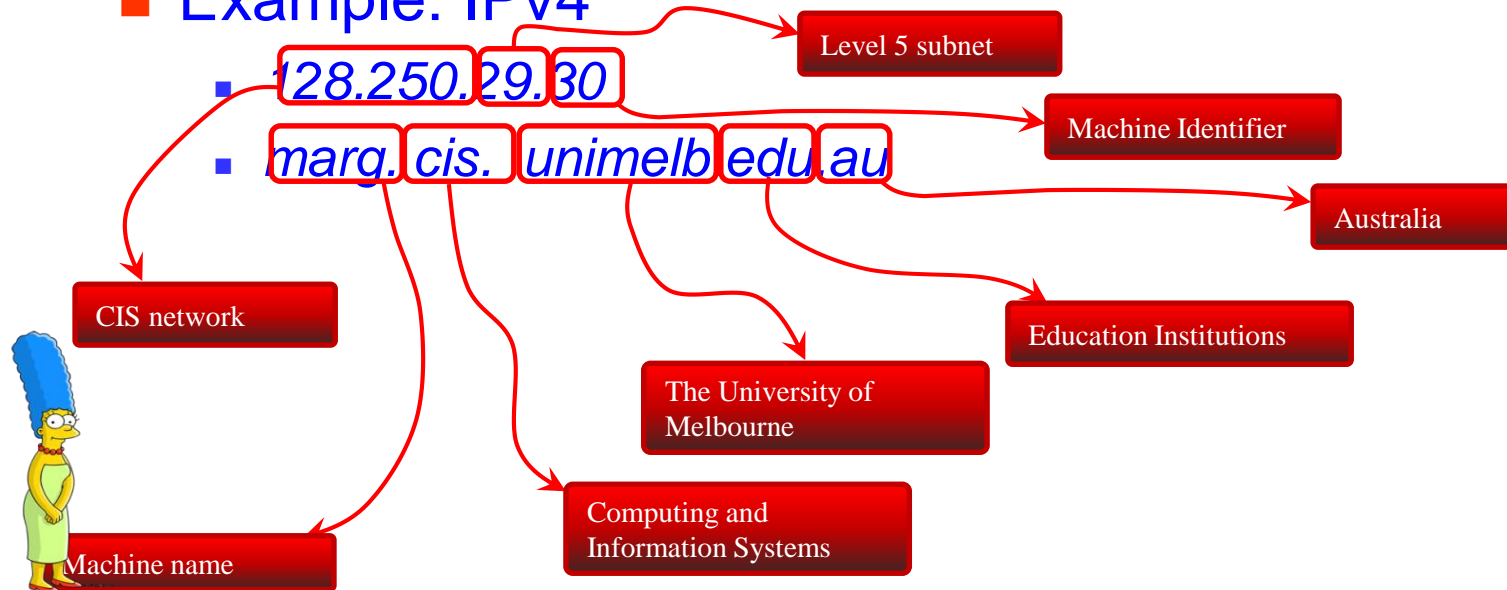

Names or Codes? or Numbers?

- As discussed in file system (hierarchical naming of files) and mounting at right location.

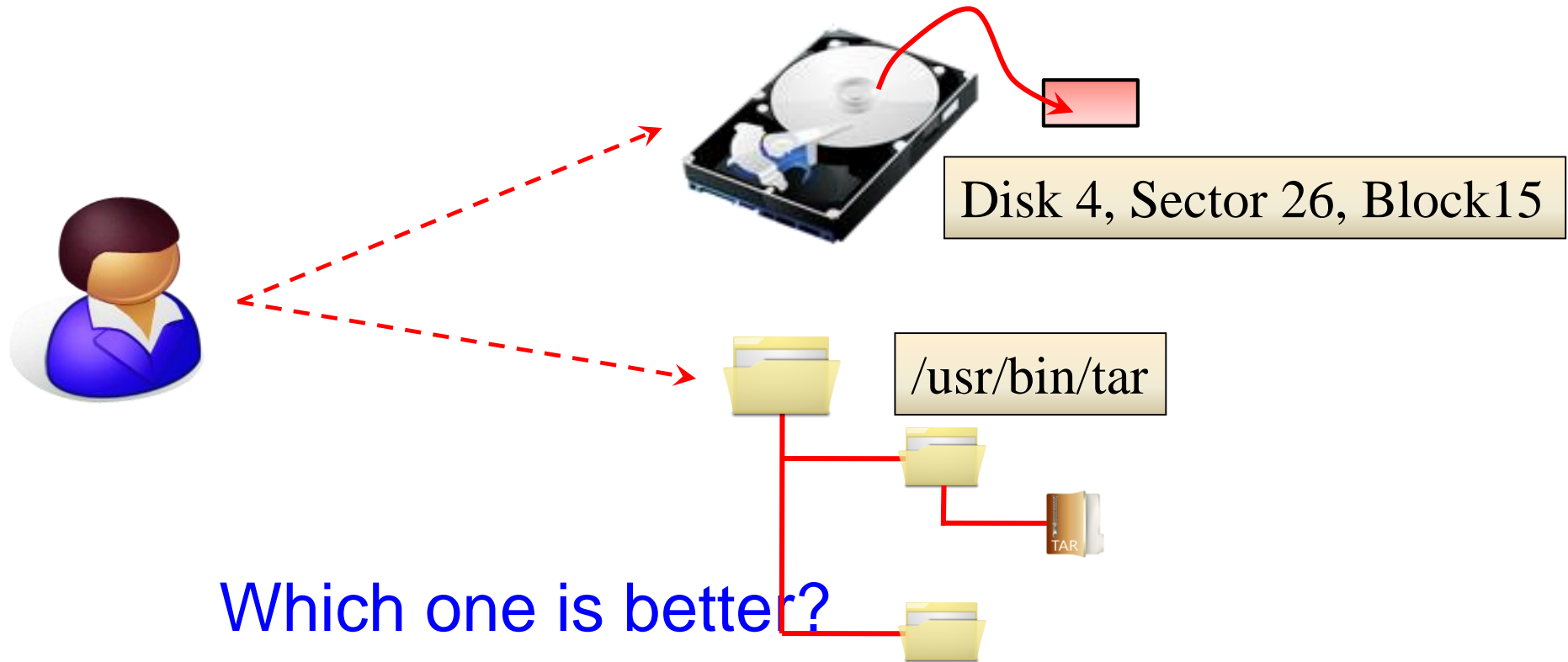

Which one is better?

Aim

- To introduce the name service as a distinct service that is used by client processes to obtain attributes such as the address of resources (computing systems, files, printers etc.) or objects when given their name.

Learning objectives

- To understand the need for naming systems in distributed systems
- To be familiar with the design requirements such as structure and management of name spaces, and operations supported by them.
- To understand the operation of the Internet naming service – DNS (Domain Name Service)
- To understand structure and operation of directory service – X.500 Directory Service & LDAP (Lightweight Directory Access Protocol)

1. Introduction

- In a distributed system, names are used to refer to **a wide variety of resources** such as:
 - Computers, services, remote objects, and files, as well as users.
- Naming is **fundamental** issue in DS design as it facilitates communication and resource sharing.
 - A name in the form of URL is needed to access a **specific web page**.
 - Processes cannot share particular resources managed by a computer system unless they can name them **consistently**
 - Users cannot communicate within one another via a DS unless they can name one another, with email address.
- Names are not the only useful means of identification: descriptive attributes are another.

What are Naming Services?

- How do Naming Services facilitate communication and resource sharing?
 - An URL facilitates the localization of a resource exposed on the Web.
 - *e.g., [abc.net.au](#) means it is likely to be an Australian entity?*
 - A consistent and uniform naming helps processes in a distributed system to interoperate and manage resources.
 - *e.g., commercials use [.com](#); non-profit organizations use [.org](#)*
 - *[.edu](#), [ac.uk](#) or [edu.au](#) educational institutes*
 - Users refer to each other by means of their names (i.e. email) rather than their system ids
 - Naming Services are not only useful to locate resources but also to gather additional information about them such as attributes

What are Naming Services?

■ Definition

In a Distributed System, a **Naming Service** is a specific service whose aim is to **provide a consistent and uniform naming of resources**, thus allowing other programs or services to **localize** them and **obtain** the required metadata for interacting with them.

■ Key benefits

- Resource localization
- Uniform naming
- Device independent address (e.g., you can move domain name/web site from one server to another server **seamlessly**).

The role of names and name services

- Resources are accessed using *identifier* or *reference*
 - An identifier can be stored in variables and retrieved from tables quickly
 - Identifier includes or can be transformed to an address for an object
 - E.g. NFS file handle, CORBA remote object reference
 - A *name* is human-readable value (usually a string) that can be *resolved* to an identifier or address
 - Internet domain name, file pathname, process number
 - E.g. `/etc/passwd`, `http://www.cdk5.net/`
- For many purposes, names are preferable to identifiers
 - because the binding of the named resource to a physical location is deferred and can be changed
 - because they are more meaningful to users
- Resource names are *resolved* by name services
 - to give identifiers and other useful attributes

Role of Names and Naming Services - Name Resolution

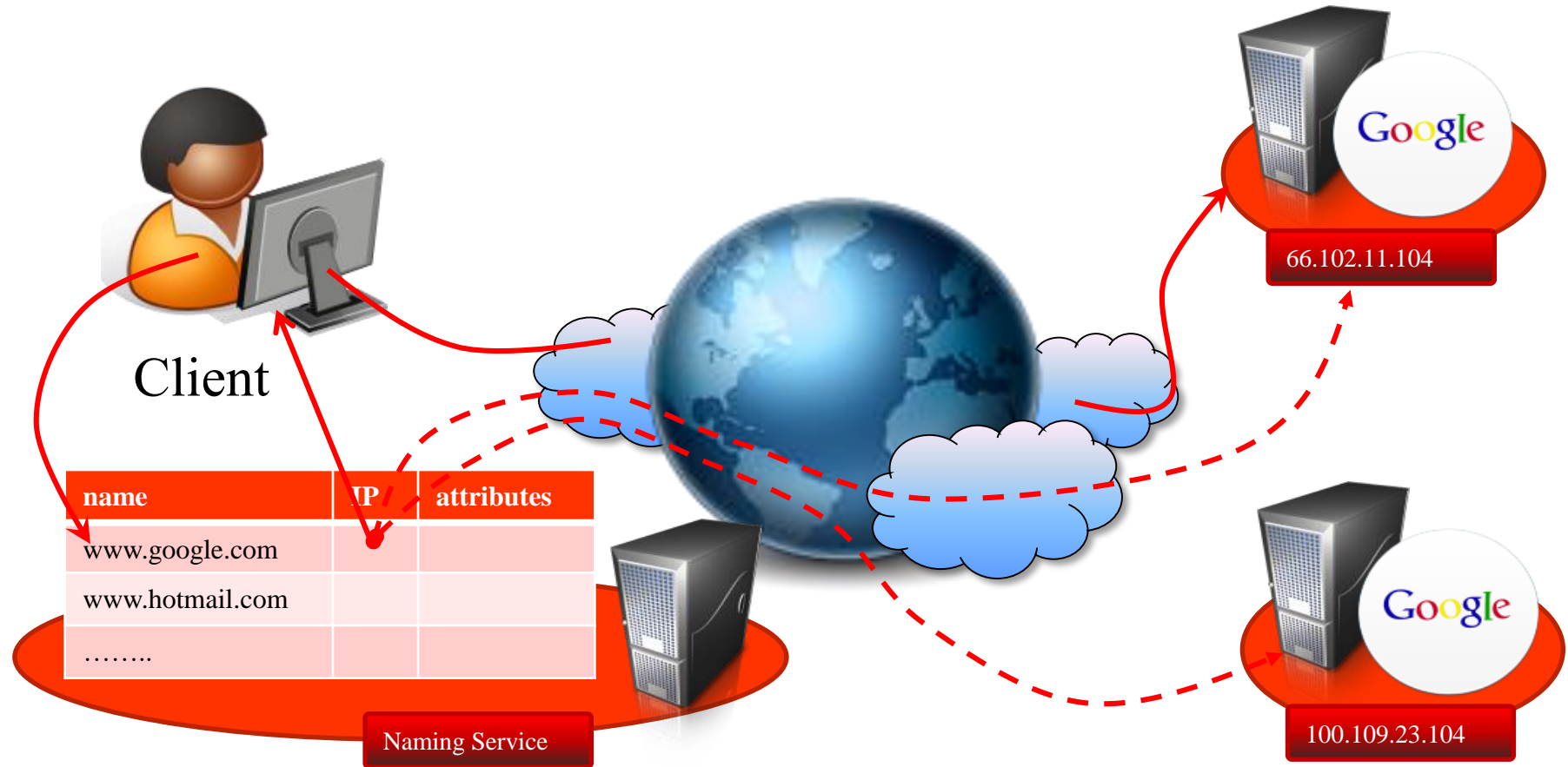

Requirements for name spaces

- Allow simple but meaningful names to be used
- Potentially infinite number of names
- Structured
 - to allow similar subnames without clashes
 - to group related names
- Allow re-structuring of name trees
 - for some types of change, old programs should continue to work
- Management of trust

No Name vs. Too Many Names

■ Game of Throne

- Arya Stark (*No name*)
- Khaleesi Daenerys Targaryen (*Daenerys Stormborn of House Targaryen, rightful heir to the Iron Throne, rightful Queen of the Andals and the First Men, Protector of the Seven Kingdoms, the Mother of Dragons, the Khaleesi of the Great Grass Sea, the Unburnt, the Breaker of Chains*)

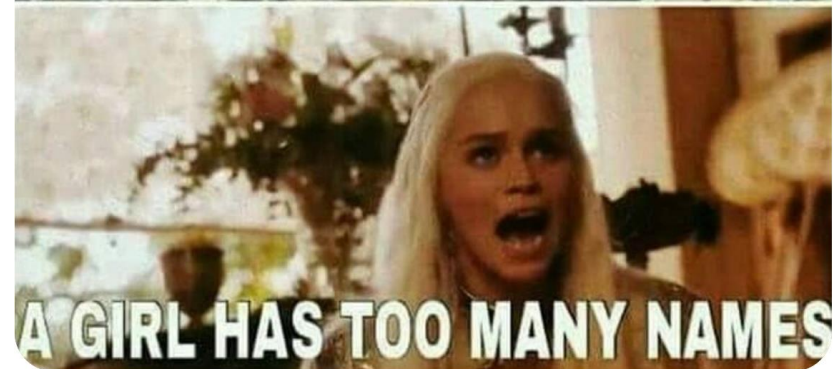

Composed naming domains used to access a resource from a URL

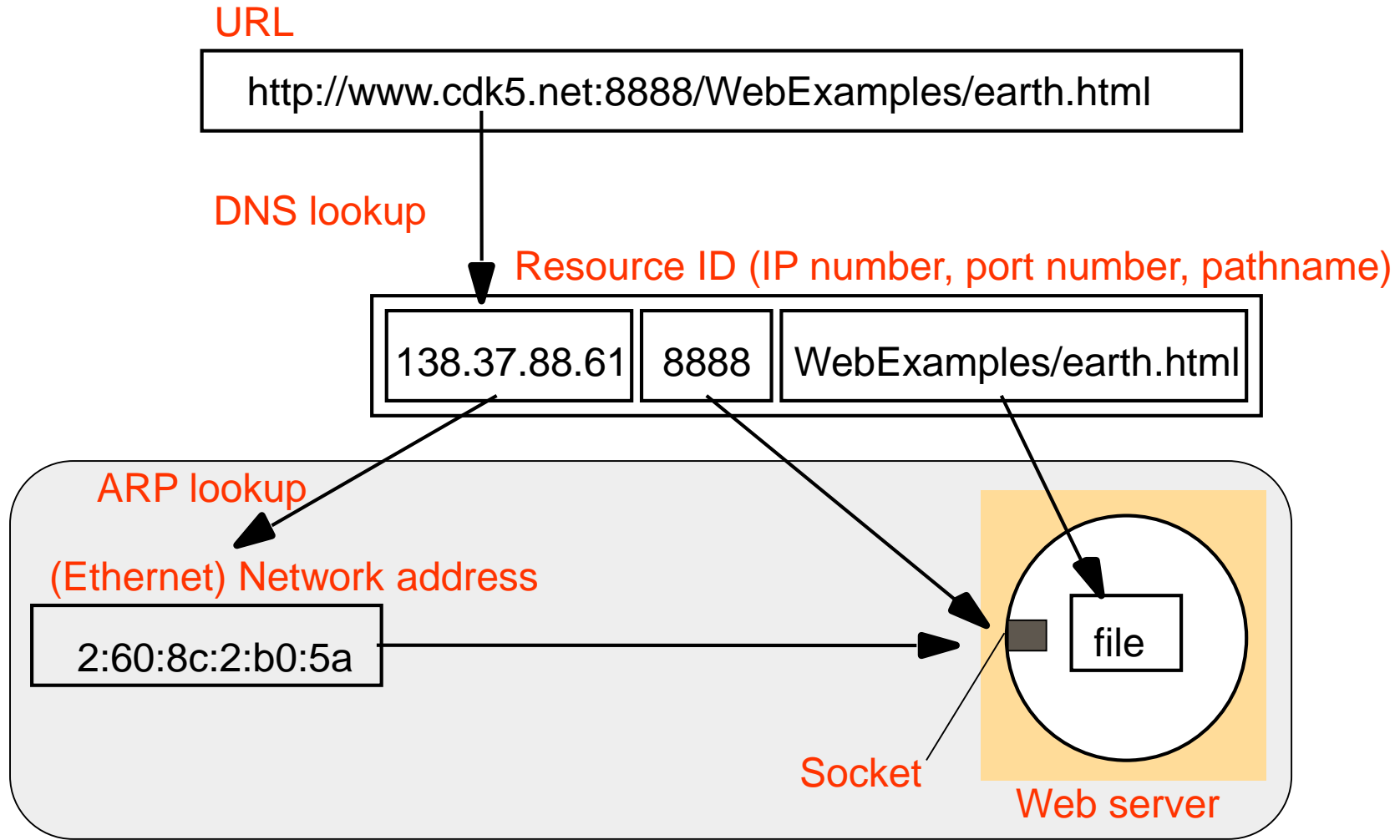

<#>

Address Resolution Protocol (ARP)

Names and resources

- Currently, different name systems are used for each type of resource:

<i>resource</i>	<i>name</i>	<i>identifies</i>
<i>file</i>	<i>pathname</i>	<i>file within a given file system</i>

More on URNs (Uniform Resource Names)

format: urn:<nameSpace>:<name-within-namespace>

examples:

- a) *urn:ISBN:021-61918-0*
- b) *urn:cloudbus.unimelb.edu.au:TR2005-10*

resolution:

- a) *send a request to nearest ISBN-lookup service - it would return whatever attributes of a book are required by the requester*
- b) *send a request to the urn lookup service at cloudbus.unimelb.edu.au - it would return a url for the relevant document*

2. Name Services and the Domain Name System



- A name service stores a collection of one or more naming contexts, sets of bindings between textual names and attributes for objects such as computers, services, and users.
- The major operation that a name service supports is to resolve names.

Navigation

- Namespaces allows for structure in names.
- URLs provide a default structure that decompose the location of a resource in
 - Navigation is the act of chaining multiple Naming Services in order to resolve a single name to the corresponding resource.
- This decomposition facilitates the resolution of the name into the corresponding resource
- Moreover, structured namespaces allows for iterative navigation...

Iterative navigation

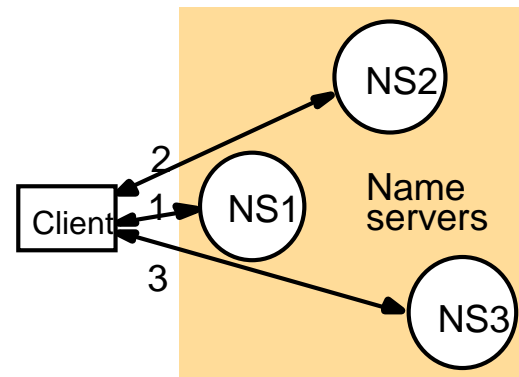

Reason for NFS iterative name resolution

This is because the file service may encounter a symbolic link (i.e. an *alias*) when resolving a name. A symbolic link must be interpreted in the client's file system name space because it may point to a file in a directory stored at another server. The client computer must determine which server this is, because only the client knows its mount points.

Server controlled navigation

- In an alternative model, name server coordinates naming resolution and returns the results to the client. It can be:
 - Recursive:
 - *it is performed by the naming server*
 - *the server becomes like a client for the next server*
 - *this is necessary in case of client connectivity constraints*
 - Non recursive:
 - *it is performed by the client or the first server*
 - *the server bounces back the next hop to its client*

Non-recursive and recursive server-controlled navigation

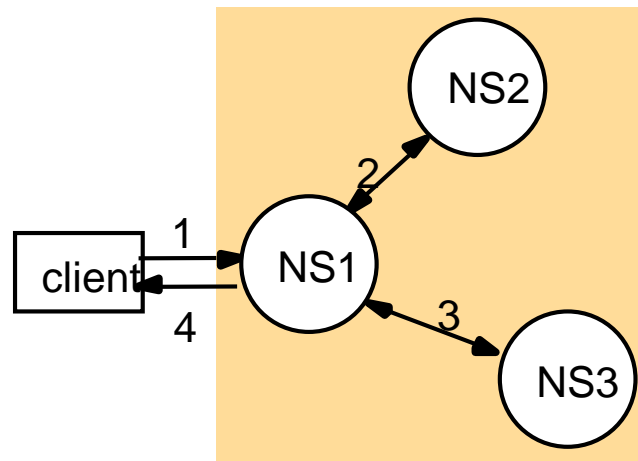

Non-recursive
server-controlled

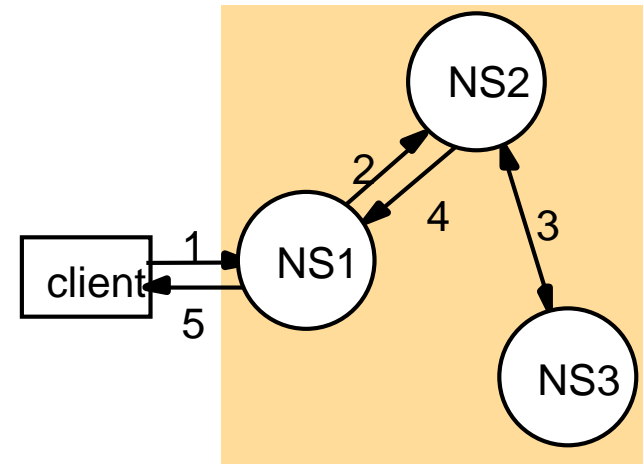

Recursive
server-controlled

A name server NS1 communicates with other name servers on behalf of a client

DNS offers recursive navigation as an option, but iterative is the standard technique. Recursive navigation must be used in domains that limit client access to their DNS information for security reasons.

DNS - The Domain Name System

- A distributed naming database (specified in RFC 1034/1305)
- Name structure reflects administrative structure of the Internet
- Rapidly resolves domain names to IP addresses
 - exploits caching heavily
 - typical query time ~100 milliseconds

Basic DNS algorithm for name resolution (domain name -> IP number)

- Look for the name in the local cache
- Try a superior DNS server, which responds with:
 - another recommended DNS server
 - the IP address (which may not be entirely up to date)

DNS name servers: Hierarchical organisation

Note: Name server names are in italics, and the corresponding domains are in parentheses. Arrows denote name server entries

authoritative path to lookup:
raj-pc.cis.unimelb.edu.au

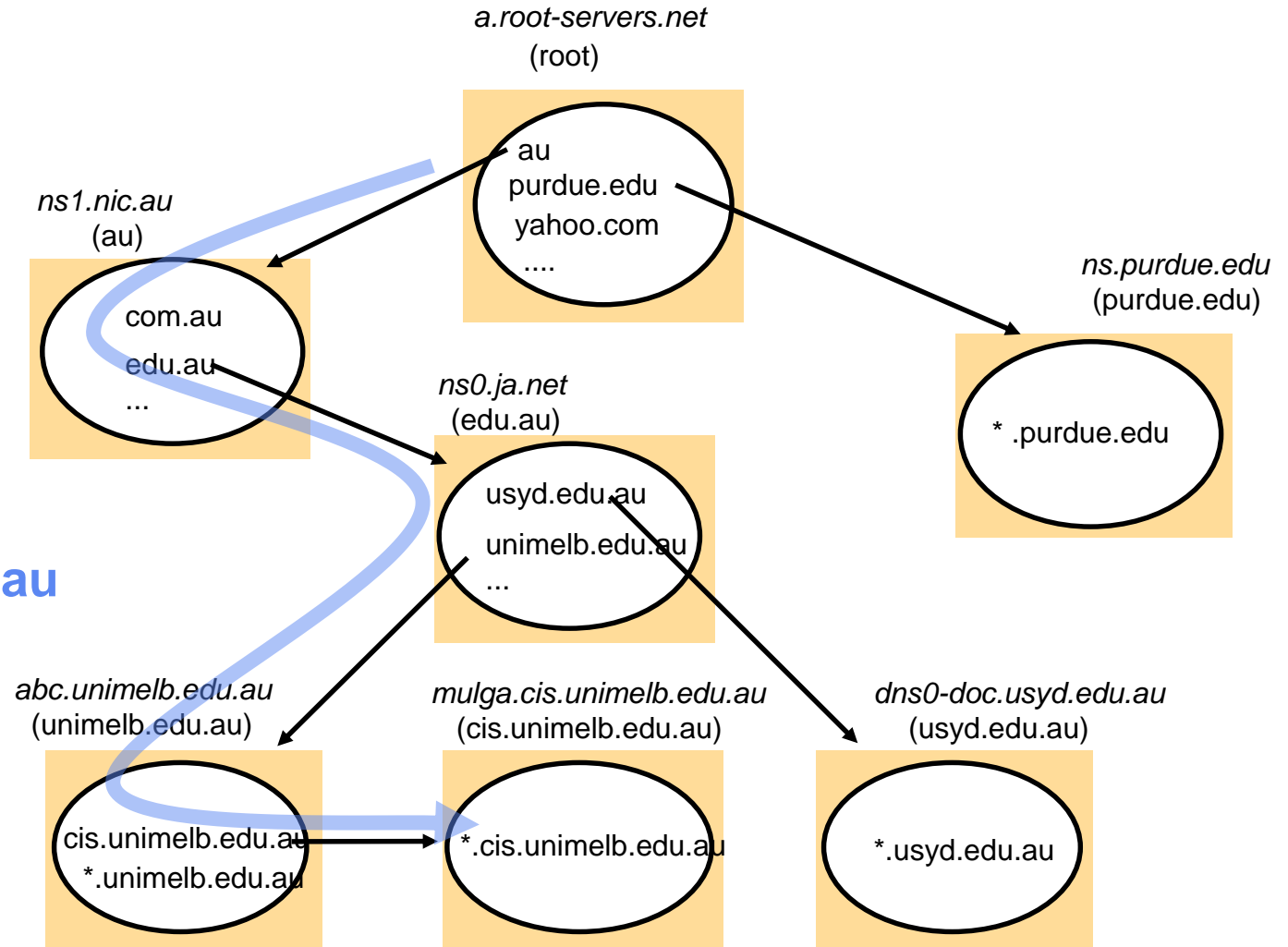

DNS in typical operation

Without caching

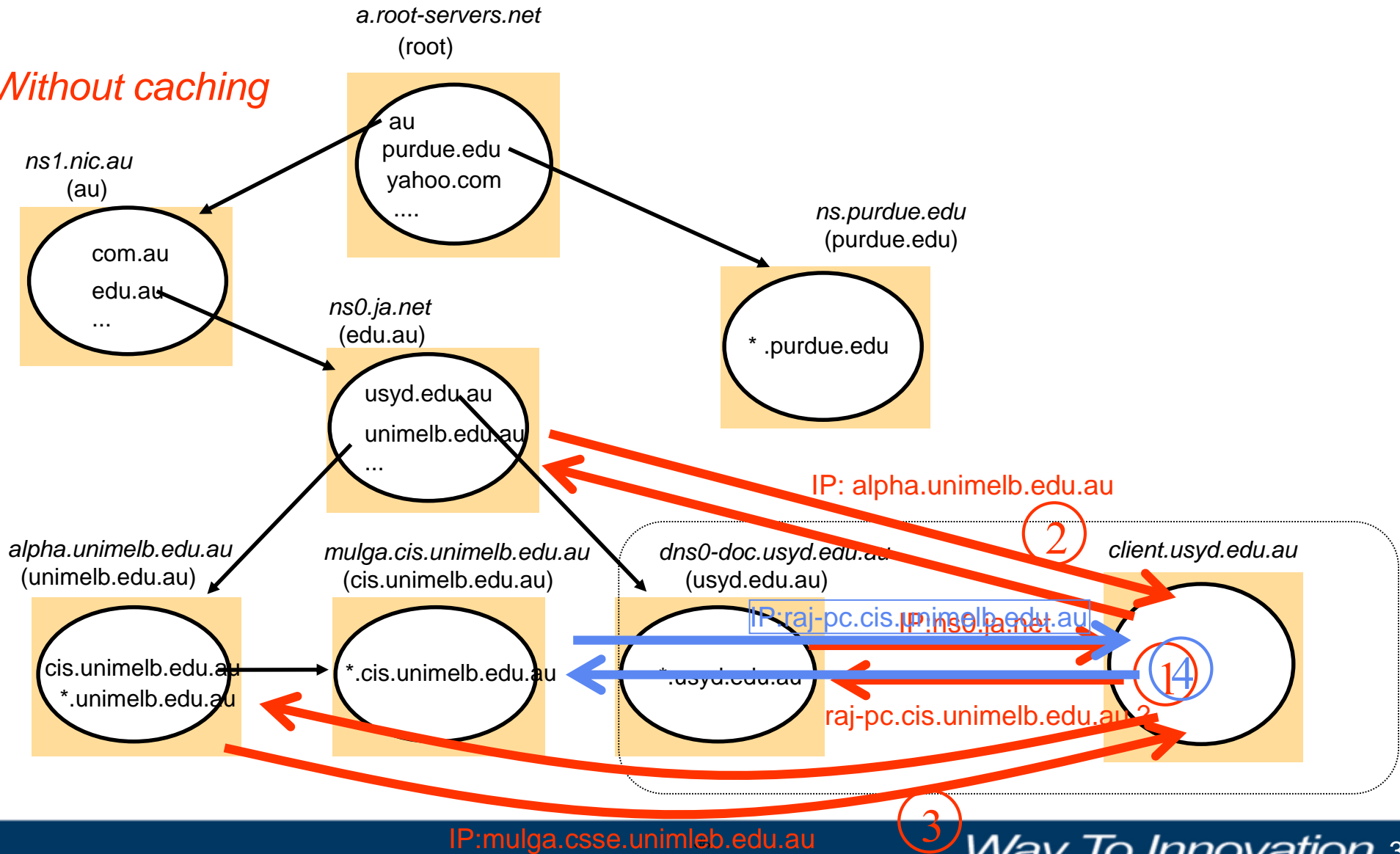

DNS server functions and configuration



- Main function is to resolve domain names for computers, i.e. to get their IP addresses
 - caches the results of previous searches until they pass their 'time to live'
- Other functions:
 - get *mail host* for a domain
 - reverse resolution - get domain name from IP address
 - Host information - type of hardware and OS
 - Well-known services - a list of well-known services offered by a host
 - Other attributes can be included (optional)

DNS resource records



<i>Record type</i>	<i>Meaning</i>	<i>Main contents</i>
A	A computer address (IPv4)	IPv4 number
AAAA	A computer address (IPv6)	IPv6 number
NS	An authoritative name server	Domain name for server
CNAME	The canonical name for an alias	Domain name for alias
SOA	Marks the start of data for a zone	Parameters governing the zone
PTR	Domain name pointer (reverse lookups)	Domain name
HINFO	Host information	Machine architecture and operating system
MX	Mail exchange	List of <preference, host> pairs
TXT	Text string	Arbitrary text

DNS issues

- Name tables change infrequently, but when they do, caching can result in the delivery of stale data.
 - Clients are responsible for detecting this and recovering
- Its design makes changes to the structure of the name space difficult. For example:
 - merging previously separate domain trees under a new root
 - moving subtrees to a different part of the structure (e.g. if Scotland became a separate country, its domains should all be moved to a new country-level domain.)

Directory services (registration and discovery)



- Sometime users wish to find a particular person or resource, but they don't know its name, only some of its attributes.
 - What is the name of the user with a telephone number **03-83441344**?
 - What is the name of professor teaching Cloud computing at SIAT (e.g., **ask Baidu!**)
- Sometime users require a service, but they are not concerned with what system entity provides it.
 - Where can I print high resolution colour image?
- Directory services can help with above situation: they store collections of bindings and attributes and also looks up entries that match attribute-based specs.
- Directory service:- 'yellow pages' for the resources in a network
 - Retrieves the set of names that satisfy a given description
 - e.g. X.500, LDAP, MS Active Directory Services
 - (*DNS holds some descriptive data, but:*
 - the data is very incomplete
 - DNS isn't organised to search it)
- Discovery service:- a directory service that also:
 - is automatically updated as the network configuration changes
 - meets the needs of clients in spontaneous networks
 - discovers services required by a client (who may be mobile) within the current *scope*, for example, to find the most suitable printing service for image files after arriving at a hotel.
 - *Examples of discovery services:* Jini discovery service, the 'service location protocol', the 'simple service discovery protocol' (part of UPnP), the 'secure discovery service'.

X.500 Directory Service

- X.500 and LDAP (Lightweight Directory Access Protocol)
 - a hierarchically-structured standard directory service designed for world-wide use
 - X.500 is standardised by ITU (international telecommunication union) and ISO
 - accommodates resource descriptions in a standard form and their retrieval for any resource (online or offline)
 - never fully deployed, but the standard forms the basis for LDAP, the Lightweight Directory Access Protocol, which is widely used – IETF RFC 2251.
 - A secure access to directory through authentication is also supported.

Part of the X.500 Directory Information Tree (DIT)

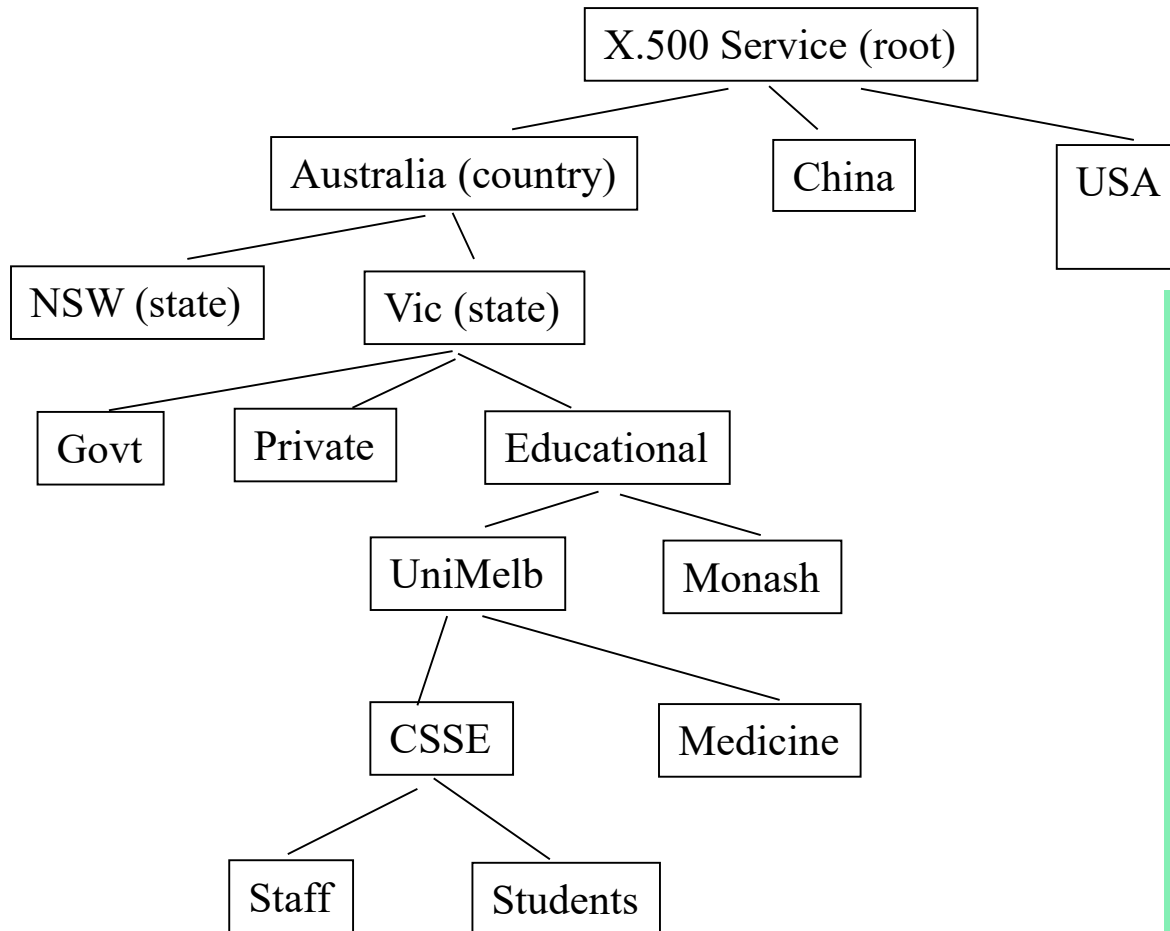

Object class for NSW govt.

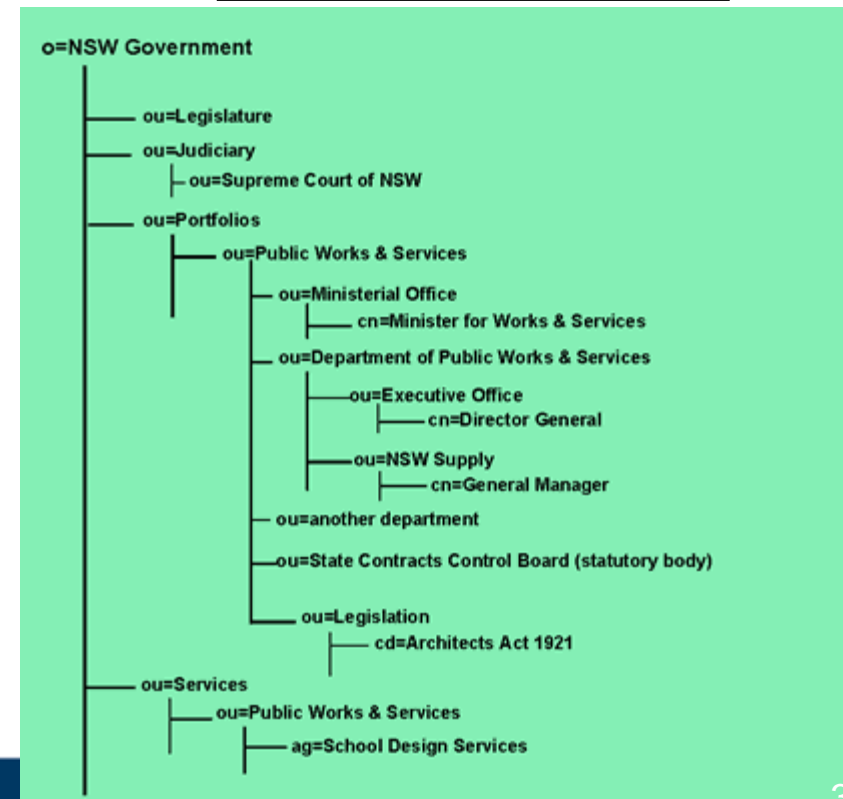

Summary

- Names services facilitate communication and resource sharing in distributed systems.
- They are playing very important role in Distributed systems such as the Internet, Web, CDNs (Content Delivery Networks), Web Services, Location-aware services– **publication and discovery**
- Name services:
 - defer the binding of resource names to addresses (and other attributes)
 - Names are resolved to give addresses and other attributes
 - Goals :
 - *Scalability (size of database, access traffic (hits/second), update traffic)*
 - *Reliability*
 - *Trust management (authority of servers)*
 - Issues
 - *exploitation of replication and caching to achieve scalability without compromising the distribution of updates*
 - *navigation methods*
- Directory and discovery services:
 - 'yellow pages' retrieval by attributes
 - dynamic resource registration and discovery

Demo



■ Sending files